

## Network And Training Breakout Modules

QCI part numbers covered by this document: QCI-BO-T, QCI-BO-N

The Network Breakout provides a simple interface to connect all required power, communication, and I/O signals to the SilverLode controller/driver SMI Port<sup>1</sup> (D15HD connector). The module's design allows for easy networking and advanced power/driver enable control.

### Network Breakout Features (QCI-BO-N)

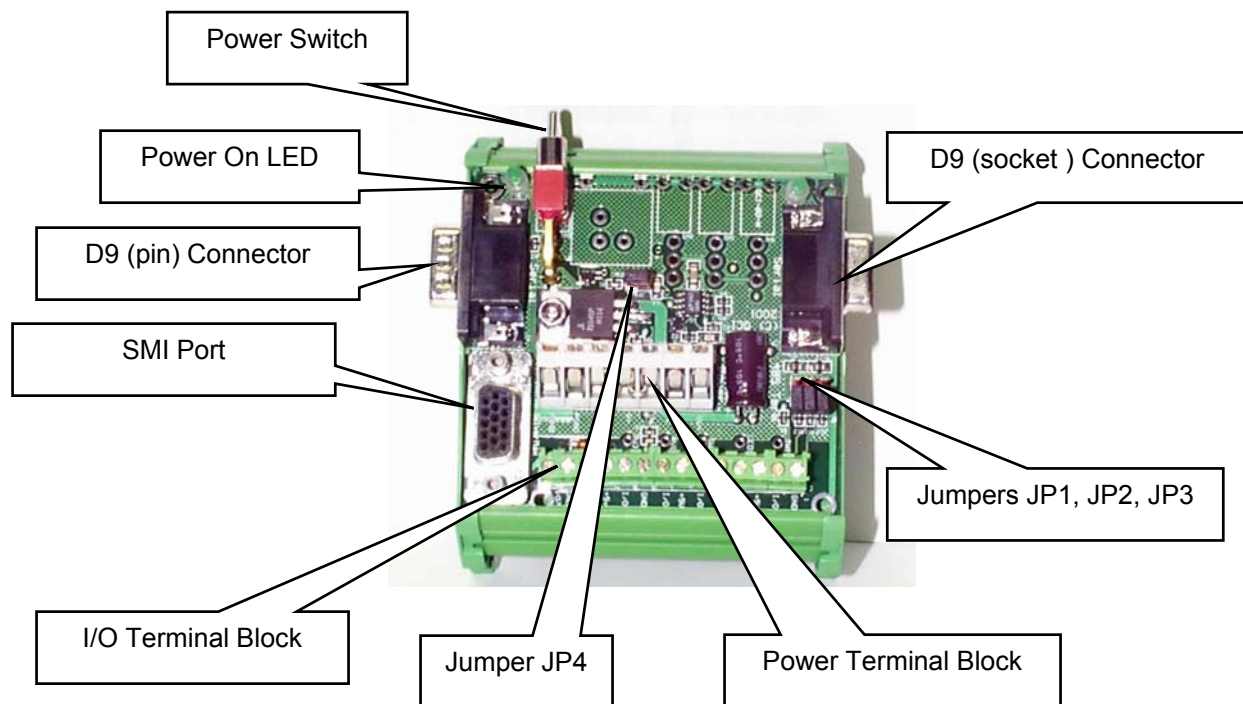

### Power Switch and Power On LED

Flip up to turn on the device attached to the SMI Port. Current goes through the Soft Start circuit to reduce arcing in the Power Switch. See Power Terminal Block below for more information on the Soft Start circuit.

<sup>1</sup> SilverLode Multifunction Interface (SMI) Port - DB15HD Connector.

### D9 Connectors and Networking

The D9 connectors provide a standard interface to the communication lines on the SMI Port. Connect the socket D9 (on right) to a standard PC D9 COM port for serial communication using a QCI Communication Cable (QCI-C-D9M9F-6).

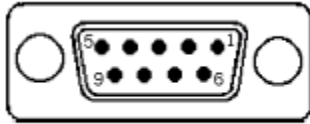

DB9 (front view)

Pins		Signal
SMI Port	D9	
2	2	RS-232 Tx
12	3	RS-232 Rx
8	5	Logic Ground

Two or more Breakout modules may be networked by connecting the D9 on one module to the D9 receptacle on another module. If multiple modules are clipped onto a DIN rail, the D9 connectors will line up such that the modules can be pushed together plugging a D9 of one module into a D9 of another module.

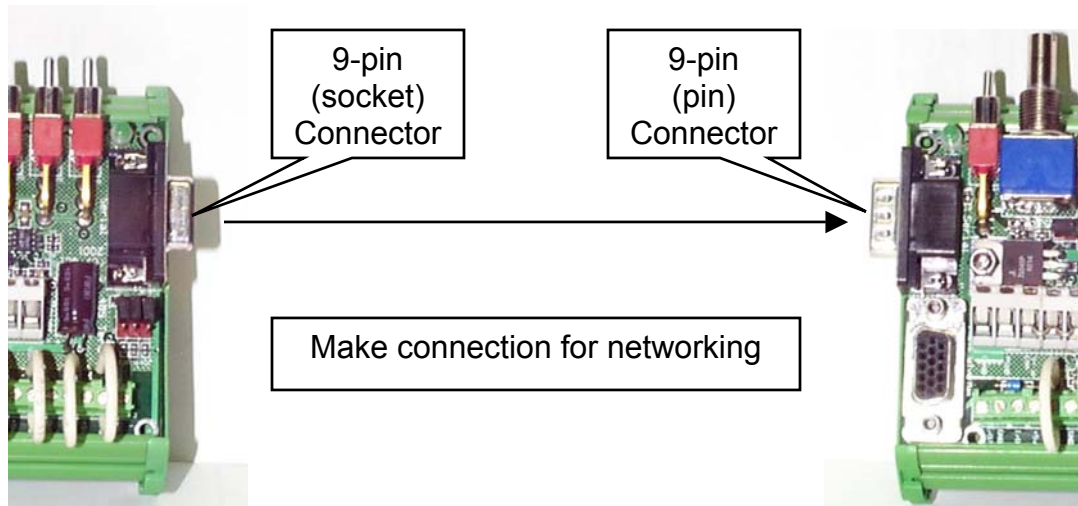

### Jumpers J1, J2, J3 – RS-485 Termination

These jumpers provide active termination for an RS-485 interface. See Serial Communication and Networking in SilverLode User Manual for more details).

	JP1,JP2,JP3
IN	RS-485
OUT	RS-232

### Power Terminal Block

The primary method for supplying power to the module is the two  $V_{in}$  terminals and the two  $PGND$  terminals on the Power Terminal Block. The  $V_{in}$  terminals send supply power to the Soft Start circuit. The Soft Start circuit provides a smooth rise in the supplied voltage. The module then re-directs this “soft” power to the  $V_o$  terminal of the Power Terminal Block. The supplied wire terminal jumpers apply the switched power to the  $V+$  and  $V+$  or  $ENA$  terminals. Multiple modules may be powered by stringing the supply voltage to each module via the  $V_{in}$  and  $PGND$  terminals.

The  $V+$  and  $V+$  or *ENA* terminals connect to SMI port power pins (1 and 7 respectively).  
 NOTE: The definitions of pins 1 and 7 are specific to the SilverLode product being used.  
 Refer to the SilverLode's datasheet for more details.

**Note:**  $V_o$  is limited to 4.0 amps. Note that if power is being supplied to multiple units from one module, the switching circuitry may be bypassed by supplying power directly to the  $V+$  and  $V+$  or *ENA* terminals. The supplied wire terminal jumpers must be removed to do this.

**Jumper JP4**

JP4 allows host control of the Soft Start. If JP4 is removed, the RTS signal on pin 7 of the 9-pin communication line must be high (asserted) to supply power to the output (i.e. terminal  $V_o$ ). In essence, the RTS signal functions as a software power switch. If JP4 is in place the Breakout will ignore the RTS signal.

JP4	
IN	Ignore RTS
OUT	Turn on Soft Start w/ RTS

**I/O Terminal Block**

The SilverLode's 7 I/O are broken out on this terminal block. Several GND and +V are also provided.

NOTE: Although the +V is labeled +5V it is only +3.3V when the breakout is attached to a SilverDust.

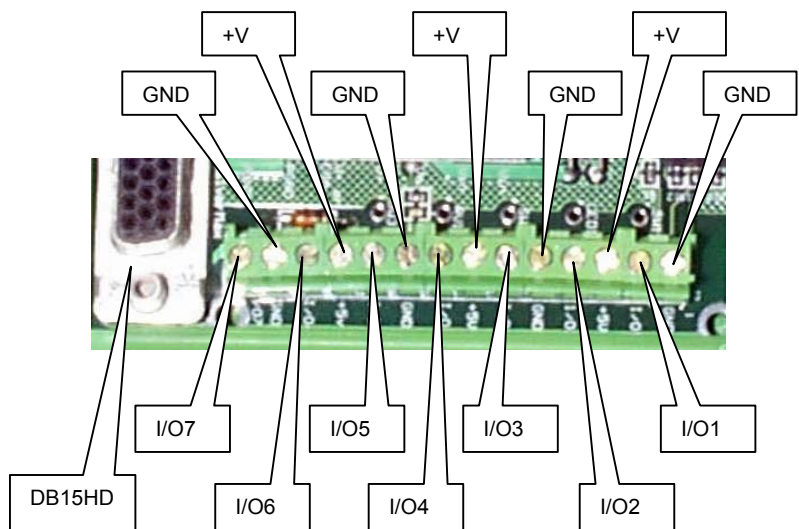

**SMI Port**

The DB15HD (socket) connector attaches to the SilverLode controller via a SMI Interface Cable (QCI-EC-SMI-nn). The pinout definition is specific to the attached SilverLode. See SilverLode controller/driver datasheets for more details.

## Training Breakout Features (QCI-BO-T)

The Training Breakout has all the features of the Network Breakout plus Test I/O.

### Test I/O Devices

- Input 4 (Analog Input 1) Potentiometer: 3/4 turn pot providing a 0 to 5V signal to Analog Input 1.
- Input 5 Switch: Press momentary pushbutton to ground Input 5 (logic 0 or FALSE).
- Input 3 Switch: Flip toggle switch down to ground Input 3 (logic 0 or FALSE).
- Input 1 Switch: Flip toggle switch down to ground Input 1 (logic 0 or FALSE).
- Output 2 LED: Clear Output 2 (logic 0 or FALSE) to light LED.

### Test I/O Jumpers

Each of the Test I/O Device devices is connected through the circuit board to a white jumper wires located near the near I/O Terminal Block. The jumpers for the Test I/O are connected via the screw terminals to their respective I/O on the I/O Terminal Block. This allows the user to change or eliminate the Test I/O.

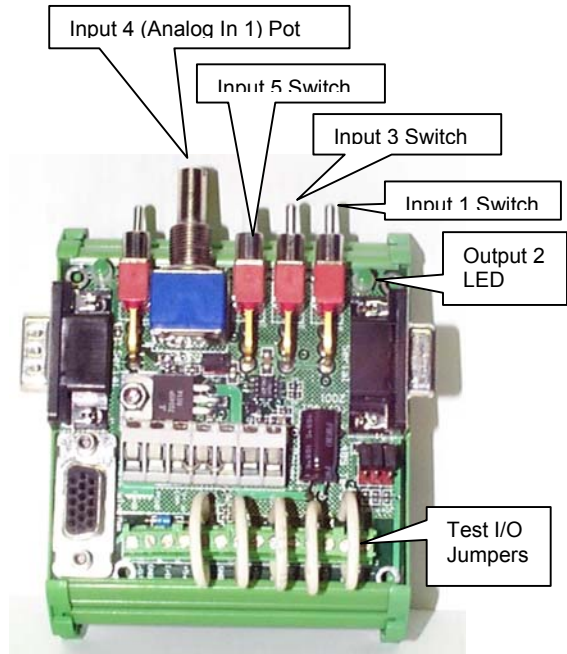

## How to Use

### Typical Training Breakout with SilverNugget N3

The SMI Port on the SilverNugget N3 does not have pins 1 & 7 tied together. Pin 1 is driver enable power while pin 7 is processor power. +10 to 48 VDC must be applied to pin 1 for the servo's drive circuitry to work. The training breakout terminal V+ is mapped to Pin 7 and V+ or ENA to Pin 1.

QCI ships the training breakout with two jumper wires as shown on the breakout, depicted by the diagram below. This configuration ties processor and driver enable to the same power supply.

Different power supply can be wired for processor and driver enable if desire. When using an alternative supply, ensure that the supply's DC common ground is connected to the SilverLode DC common ground.

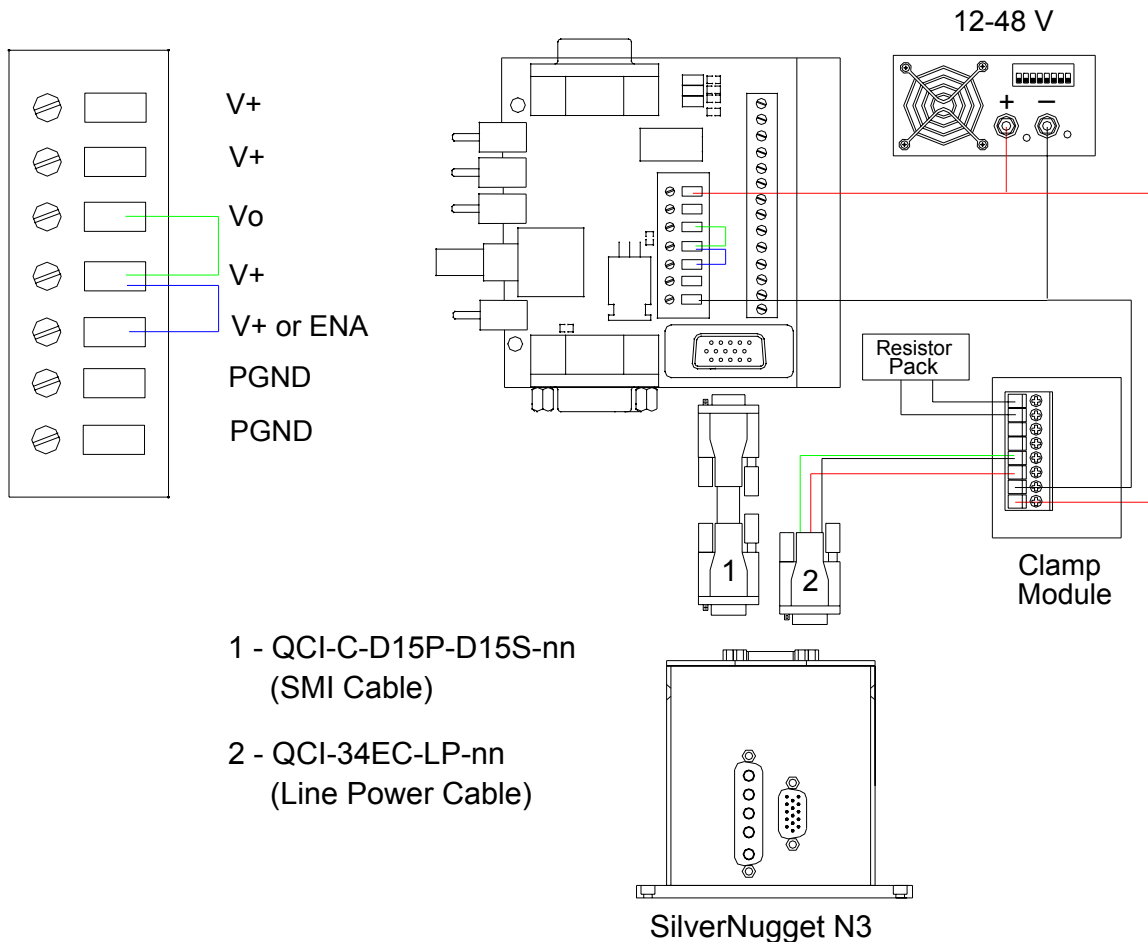

**Typical Training Breakout with SilverDust D2 (IGB)**

The SMI Port on the SilverDust D2 (IGB) has pins 1 & 7 tied together. Do not configure as the SilverNugget N3. The IGB has driver enable internally mapped and accessed only thru the terminal labeled DRV / ENA. +10 to 48 VDC must be applied to DRV / ENA for the servo's circuitry to operate.

QCI ships the SilverDust IGB with a jumper wire between Clamp + and DRV / ENA. This configuration ties DRV / ENA to Clamp +, which is approximately at the power supply level from pins 1 & 7 as depicted in the diagram.

Do not apply different potential power supply to V+ and pins 1 & 7. Higher potential PS at pins 1 & 7 will back drive the lower potential PS at V+ causing damages.

Never apply power to the IGB terminal Clamp +. Power applied will trip the clamping circuit as regenerative power and over load the power resistor and eventually damage the clamping circuit.

When using an alternative supply, ensure that the supply's DC common ground is connected to the SilverLode DC common ground.

